

1:	*10.3 ↘
2:	*10.7 ↓
3:	10.1 ↗
4:	*10.7 →
5:	10.1 ↙
6:	*10.4 ↘
7:	9.9 ↑
8:	9.8 →
9:	*10.7 ↓
10:	*10.7 ↘
Serie	103.4
Total	103.4

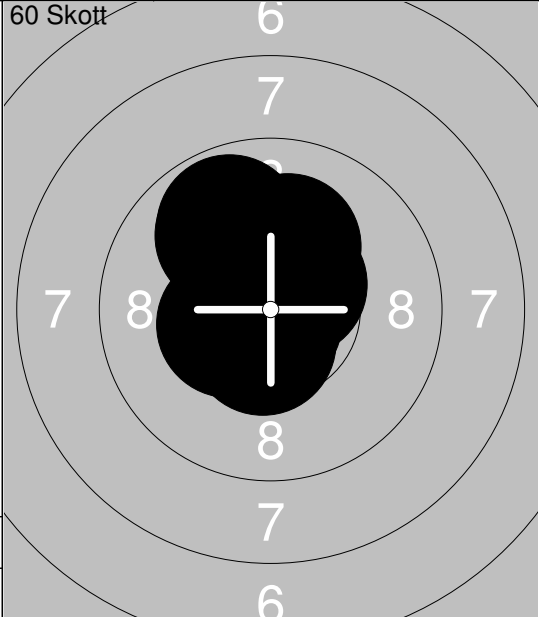

11:	*10.6 ↘
12:	*10.5 ↓
13:	9.8 ↗
14:	*10.7 ↘
15:	*10.5 ↑
16:	10.1 ↑
17:	*10.5 ↗
18:	9.9 ↘
19:	*10.4 ↙
20:	*10.8 ↓
Serie	103.8
Total	207.2

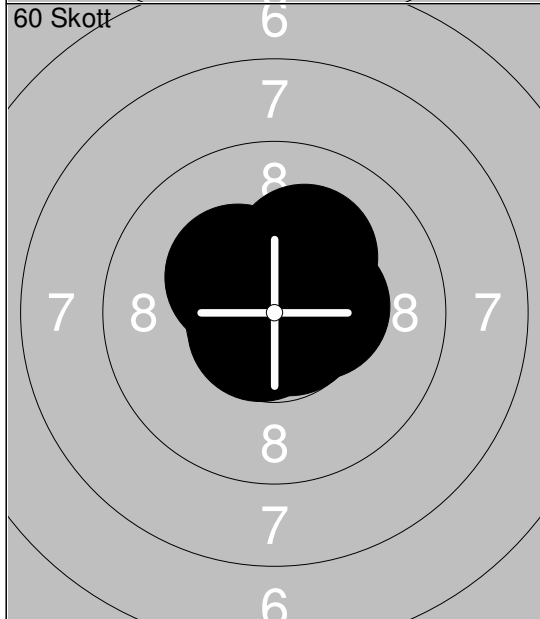

21:	*10.3 ↘
22:	*10.7 ↓
23:	*10.5 ↑
24:	*10.4 →
25:	*10.7 →
26:	*10.7 ↑
27:	*10.2 ↗
28:	*10.8 ↗
29:	*10.8 →
30:	*10.6 →
Serie	105.7
Total	312.9

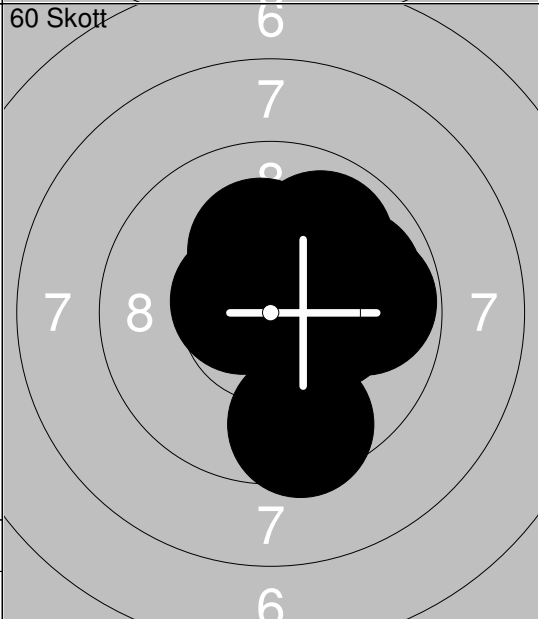

31:	9.5 ↓
32:	9.8 →
33:	*10.6 ↘
34:	*10.7 ↗
35:	9.9 ↗
36:	9.9 →
37:	10.1 ↗
38:	*10.3 →
39:	*10.2 ↑
40:	*10.7 ↑
Serie	101.7
Total	414.6

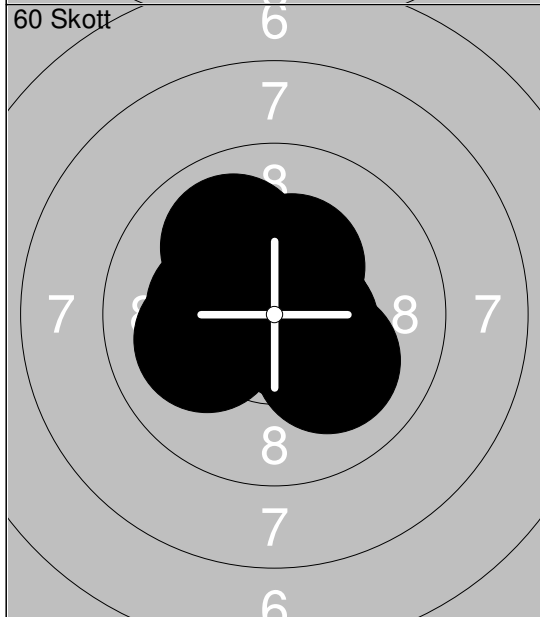

41:	10.0 ↘
42:	*10.3 ↑
43:	*10.6 →
44:	10.1 ↙
45:	*10.8 ↑
46:	*10.6 →
47:	10.1 ↓
48:	*10.6 →
49:	*10.3 ↙
50:	*10.7 ↙
Serie	104.1
Total	518.7

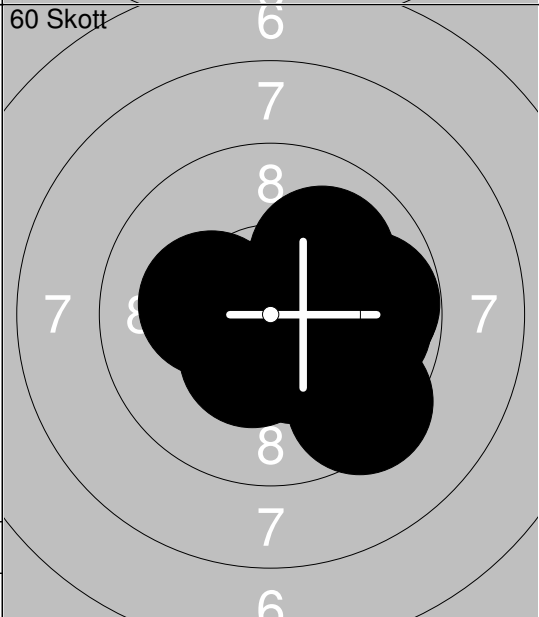



51:	9.8 →
52:	*10.4 ↓
53:	9.8 →
54:	*10.4 ↓
55:	*10.7 ↗
56:	*10.2 ↘
57:	9.9 →
58:	9.4 ↓
59:	*10.7 →
60:	10.0 ↗
Serie	101.3
Total	620.0

<p>60 Skott</p>	<p>1: *10.6 ↘                  2: *10.6 ←                  3: 9.9 →                  4: 9.9 ↘                  5: *10.2 →                  6: *10.4 ←                  7: *10.4 ↘                  8: *10.3 →                  9: 10.0 →                  10: *10.6 ←</p> <table border="1" style="width:100%; border-collapse: collapse;"> <tr><td>Serie</td><td style="text-align: right;">102.9</td></tr> <tr><td>Total</td><td style="text-align: right;">102.9</td></tr> </table>	Serie	102.9	Total	102.9	<p>60 Skott</p>	<p>11: *10.6 ↘                  12: 9.7 ↖                  13: *10.6 →                  14: *10.4 ↘                  15: *10.3 ↘                  16: 9.8 →                  17: *10.6 ↗                  18: 10.0 →                  19: *10.6 ↘                  20: 10.1 ←</p> <table border="1" style="width:100%; border-collapse: collapse;"> <tr><td>Serie</td><td style="text-align: right;">102.7</td></tr> <tr><td>Total</td><td style="text-align: right;">205.6</td></tr> </table>	Serie	102.7	Total	205.6
Serie	102.9										
Total	102.9										
Serie	102.7										
Total	205.6										
<p>60 Skott</p>	<p>21: *10.4 ↘                  22: *10.6 ←                  23: *10.5 →                  24: *10.6 ←                  25: 10.0 ←                  26: *10.8 ↘                  27: 9.9 →                  28: *10.7 ↘                  29: *10.4 ←                  30: *10.3 ↘</p> <table border="1" style="width:100%; border-collapse: collapse;"> <tr><td>Serie</td><td style="text-align: right;">104.2</td></tr> <tr><td>Total</td><td style="text-align: right;">309.8</td></tr> </table>	Serie	104.2	Total	309.8	<p>60 Skott</p>	<p>31: 10.1 ↖                  32: *10.4 ↘                  33: 9.8 ↓                  34: *10.7 ↘                  35: *10.2 →                  36: *10.5 ↘                  37: *10.4 →                  38: *10.7 ↘                  39: *10.6 ↘                  40: 9.7 ↓</p> <table border="1" style="width:100%; border-collapse: collapse;"> <tr><td>Serie</td><td style="text-align: right;">103.1</td></tr> <tr><td>Total</td><td style="text-align: right;">412.9</td></tr> </table>	Serie	103.1	Total	412.9
Serie	104.2										
Total	309.8										
Serie	103.1										
Total	412.9										
<p>60 Skott</p>	<p>41: 9.8 →                  42: *10.3 ←                  43: *10.4 →                  44: 9.9 ←                  45: 9.6 ←                  46: 10.1 ←                  47: 9.8 ↘                  48: *10.6 ↘                  49: *10.5 ↘                  50: *10.9 ←</p> <table border="1" style="width:100%; border-collapse: collapse;"> <tr><td>Serie</td><td style="text-align: right;">101.9</td></tr> <tr><td>Total</td><td style="text-align: right;">514.8</td></tr> </table>	Serie	101.9	Total	514.8	<p>60 Skott</p>	<p>51: 10.1 ←                  52: *10.7 ↘                  53: *10.8 ↘                  54: *10.2 ↖                  55: *10.2 ↘                  56: 10.1 ↘                  57: 9.9 ←                  58: 9.6 ←                  59: *10.2 ←                  60: *10.7 ↘</p> <table border="1" style="width:100%; border-collapse: collapse;"> <tr><td>Serie</td><td style="text-align: right;">102.5</td></tr> <tr><td>Total</td><td style="text-align: right;">617.3</td></tr> </table>	Serie	102.5	Total	617.3
Serie	101.9										
Total	514.8										
Serie	102.5										
Total	617.3										

<p>60 Skott</p>	<p>60 Skott</p>
<p>60 Skott</p>	<p>60 Skott</p>
<p>60 Skott</p>	<p>60 Skott</p>

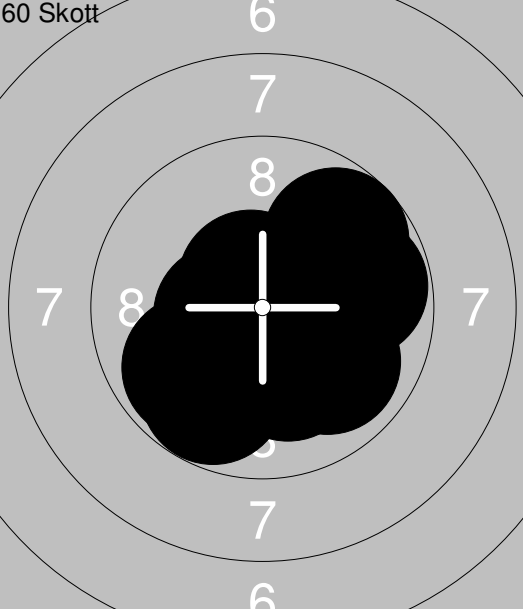
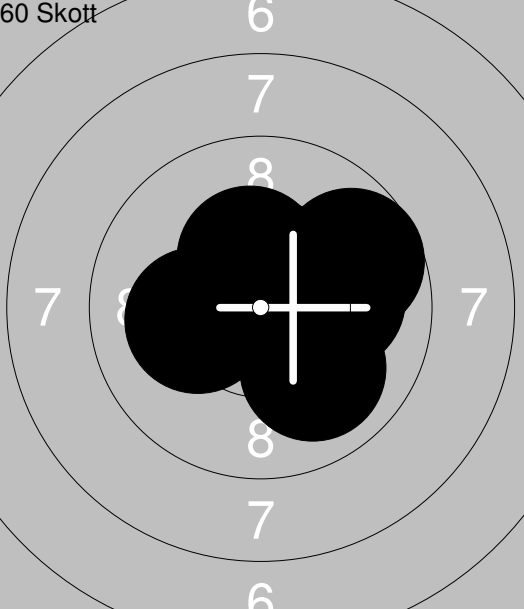
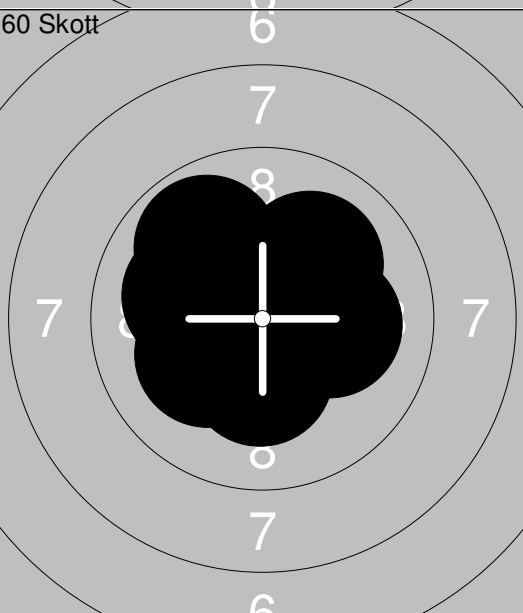
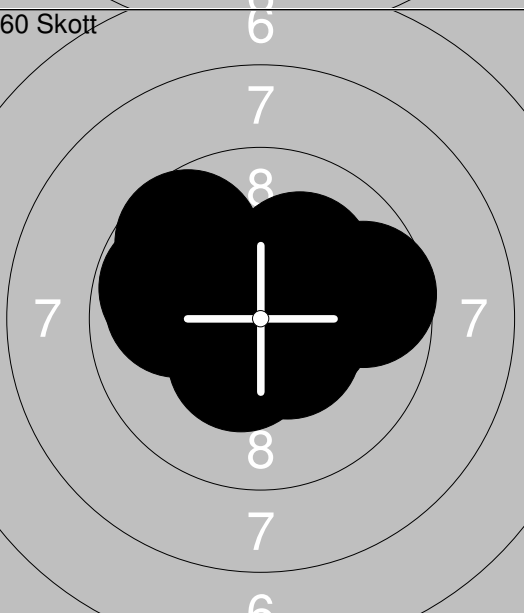
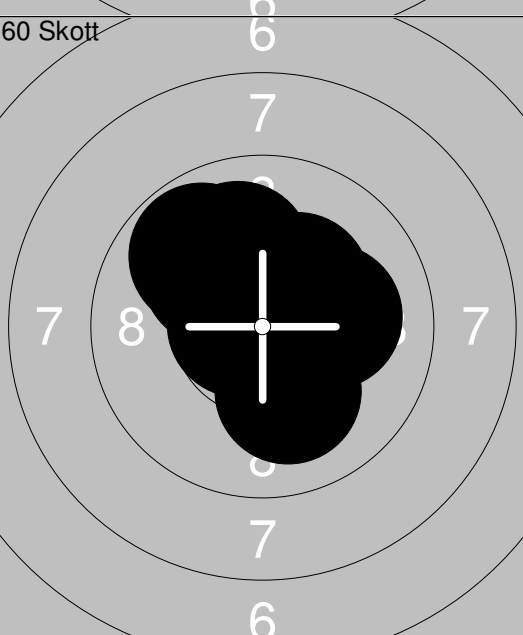
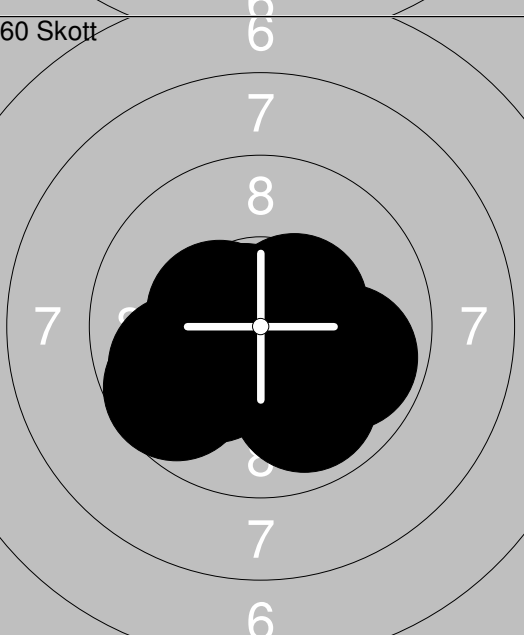
<p>60 Skott</p>	<p>60 Skott</p>
<p>60 Skott</p>	<p>60 Skott</p>
<p>60 Skott</p>	<p>60 Skott</p>

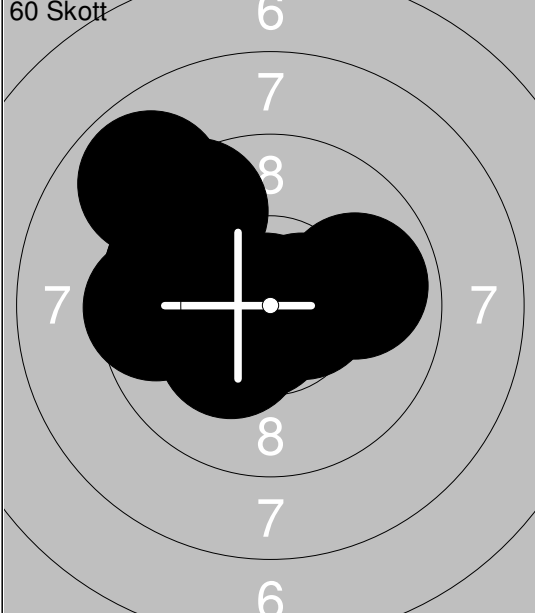
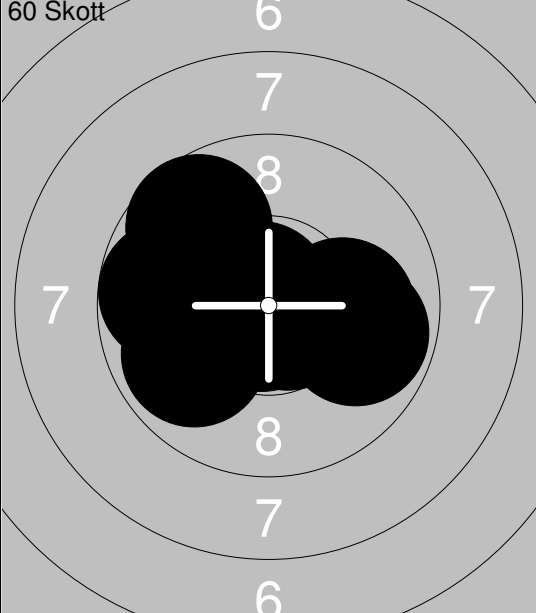
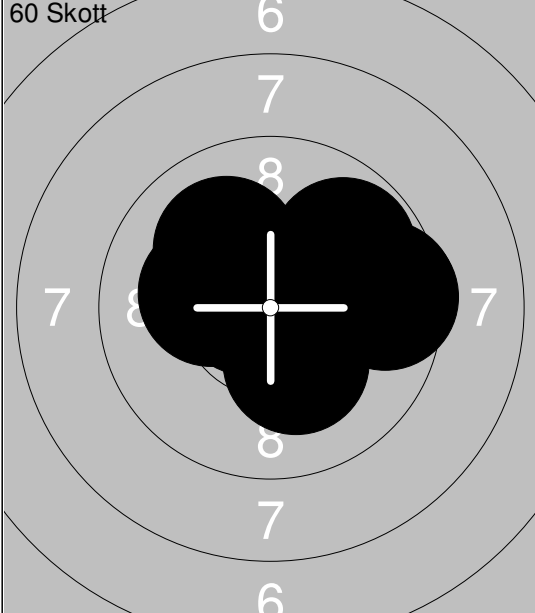
<p>60 Skott</p> 	<p>1: *10.5 ←</p> <p>2: *10.2 ↓</p> <p>3: 9.8 ↓</p> <p>4: *10.6 ↖</p> <p>5: 9.9 ↙</p> <p>6: 9.8 →</p> <p>7: 9.7 ↗</p> <p>8: *10.4 ↗</p> <p>9: 9.9 ↘</p> <p>10: *10.2 ↓</p> <hr/> <p>Serie 101.0</p> <hr/> <p>Total 101.0</p>	<p>60 Skott</p> 	<p>11: *10.3 →</p> <p>12: 10.1 →</p> <p>13: *10.2 →</p> <p>14: *10.2 ←</p> <p>15: *10.5 ↗</p> <p>16: *10.5 →</p> <p>17: 9.7 ↗</p> <p>18: *10.3 ↗</p> <p>19: *10.5 →</p> <p>20: 10.0 ↓</p> <hr/> <p>Serie 102.3</p> <hr/> <p>Total 203.3</p>
<p>60 Skott</p> 	<p>21: 10.1 →</p> <p>22: *10.3 ↓</p> <p>23: 10.1 ←</p> <p>24: *10.6 ←</p> <p>25: *10.6 ↓</p> <p>26: *10.8 ↖</p> <p>27: *10.2 ↙</p> <p>28: 10.1 ↗</p> <p>29: *10.3 ←</p> <p>30: 9.9 ↖</p> <hr/> <p>Serie 103.0</p> <hr/> <p>Total 306.3</p>	<p>60 Skott</p> 	<p>31: *10.5 →</p> <p>32: 9.7 ↖</p> <p>33: *10.9 ↖</p> <p>34: *10.4 ↓</p> <p>35: *10.5 ↓</p> <p>36: 9.9 ←</p> <p>37: 9.7 →</p> <p>38: 9.8 ←</p> <p>39: *10.8 ↓</p> <p>40: 10.1 ↗</p> <hr/> <p>Serie 102.3</p> <hr/> <p>Total 408.6</p>
<p>60 Skott</p> 	<p>41: 10.0 ↗</p> <p>42: 9.8 ↖</p> <p>43: *10.3 ↗</p> <p>44: *10.3 →</p> <p>45: 10.1 ↓</p> <p>46: 10.1 →</p> <p>47: *10.3 ↗</p> <p>48: *10.2 ↖</p> <p>49: 10.1 ↖</p> <p>50: *10.7 ←</p> <hr/> <p>Serie 101.9</p> <hr/> <p>Total 510.5</p>	<p>60 Skott</p> 	<p>51: *10.4 →</p> <p>52: *10.7 ↖</p> <p>53: *10.4 ↓</p> <p>54: 9.9 ↓</p> <p>55: *10.2 ↙</p> <p>56: *10.4 ←</p> <p>57: *10.5 →</p> <p>58: 9.9 ←</p> <p>59: 9.9 →</p> <p>60: 9.7 ↙</p> <hr/> <p>Serie 102.0</p> <hr/> <p>Total 612.5</p>

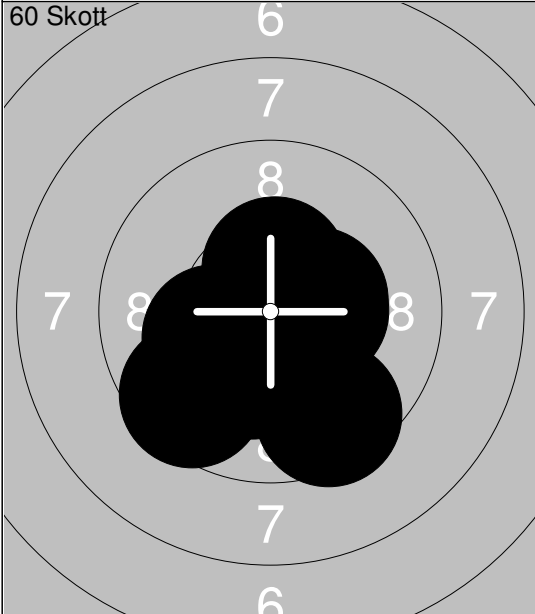
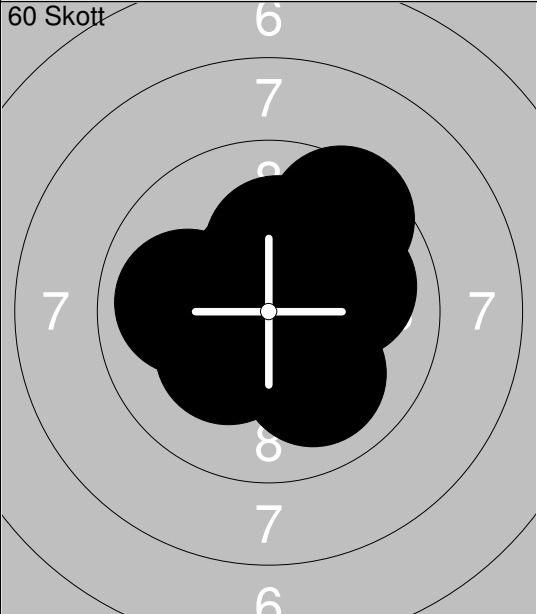
60 Skott		1: 9.9 → 2: 9.8 ← 3: 9.6 ← 4: 9.5 ↗ 5: *10.6 ↘ 6: 8.9 ↗ 7: *10.3 ↘ 8: *10.6 → 9: *10.7 ↘ 10: *10.9 ↘ Serie 100.8 Total 100.8	60 Skott		11: *10.5 ↘ 12: *10.8 ↘ 13: *10.6 ↘ 14: 9.9 ← 15: 9.8 ← 16: 9.8 → 17: *10.7 → 18: *10.8 ↗ 19: 9.7 ↗ 20: 10.0 → Serie 102.6 Total 203.4
60 Skott		21: *10.7 ↘ 22: 9.8 ↗ 23: 9.5 → 24: 9.6 → 25: *10.4 ↗ 26: 10.1 ↗ 27: *10.2 ↘ 28: *10.4 ↘ 29: *10.5 → 30: *10.2 ↘ Serie 101.4 Total 304.8	60 Skott		31: *10.8 → 32: *10.3 ↘ 33: 10.0 ↗ 34: *10.7 ↘ 35: *10.4 ↑ 36: 10.1 ↑ 37: *10.7 ↑ 38: 10.1 ↓ 39: *10.7 ↘ 40: *10.3 → Serie 104.1 Total 408.9
60 Skott		41: *10.4 ↑ 42: 9.6 ↘ 43: *10.4 → 44: *10.7 ↘ 45: *10.8 ↘ 46: *10.4 → 47: *10.7 ↑ 48: *10.2 ↘ 49: 9.5 ↓ 50: *10.2 ↘ Serie 102.9 Total 511.8	60 Skott		51: 10.0 → 52: *10.5 → 53: 10.0 ↘ 54: *10.8 ↘ 55: 10.0 ← 56: *10.3 ↘ 57: 9.5 ↗ 58: *10.2 ↑ 59: *10.7 ↗ 60: *10.5 ↑ Serie 102.5 Total 614.3

<p>60 Skott</p>	<p>1: 9.4 ↘                  2: 9.4 ↘                  3: *10.6 ↘                  4: *10.2 ↘                  5: 10.1 ←                  6: *10.2 →                  7: 9.5 ↘                  8: *10.4 ←                  9: 9.8 →                  10: 10.0 ←</p> <p>Serie 99.6 Total 99.6</p>	<p>60 Skott</p>	<p>11: *10.6 ↘                  12: 9.9 ↘                  13: *10.4 →                  14: 9.9 ←                  15: *10.4 →                  16: *10.2 ↘                  17: 10.0 →                  18: *10.4 ↘                  19: 9.9 ↘                  20: *10.3 →</p> <p>Serie 102.0 Total 201.6</p>
<p>60 Skott</p>	<p>21: 10.1 ↘                  22: 9.5 →                  23: 9.9 ↘                  24: 10.0 →                  25: *10.4 ↗                  26: 10.0 ↘                  27: 8.9 →                  28: *10.6 ↘                  29: 10.1 →                  30: *10.6 ↘</p> <p>Serie 100.1 Total 301.7</p>	<p>60 Skott</p>	<p>31: 9.5 ↘                  32: 10.0 ↘                  33: 10.0 →                  34: 9.9 ↘                  35: 9.8 ←                  36: 9.7 ↘                  37: 10.0 →                  38: 9.3 →                  39: 10.0 →                  40: *10.5 ↘</p> <p>Serie 98.7 Total 400.4</p>
<p>60 Skott</p>	<p>41: 9.7 ←                  42: *10.3 ↘                  43: *10.7 ↗                  44: *10.6 ↑                  45: *10.9 ↗                  46: *10.2 ↗                  47: *10.2 ↘                  48: 9.6 ←                  49: *10.3 ↘                  50: 8.8 ↘</p> <p>Serie 101.3 Total 501.7</p>	<p>60 Skott</p>	<p>51: *10.3 →                  52: 8.9 →                  53: 10.0 ←                  54: *10.4 ↘                  55: 10.1 ←                  56: 9.8 ↘                  57: 10.1 ↘                  58: 9.1 ←                  59: 9.3 ↘                  60: *10.3 ↘</p> <p>Serie 98.3 Total 600.0</p>

60 Skott

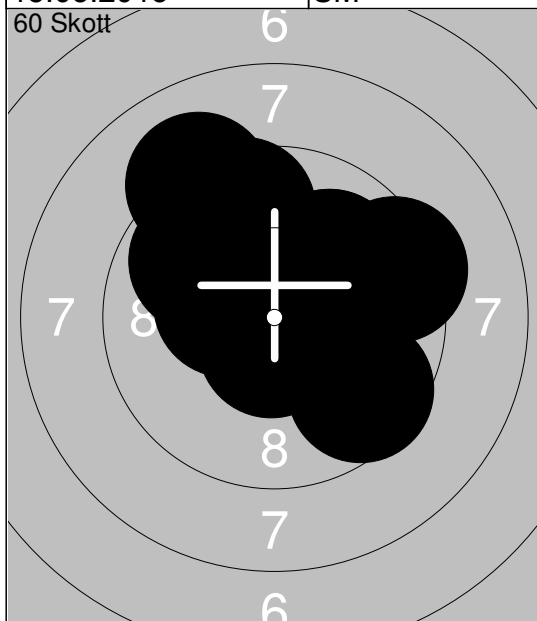

1: 9.6 ↘  
 2: 10.0 ↗  
 3: \*10.3 ↘  
 4: \*10.6 ↓  
 5: 9.6 ↑  
 6: 10.0 ↗  
 7: \*10.2 ↑  
 8: 9.1 ↖  
 9: 9.8 ↖  
 10: 9.4 →

Serie 98.6

Total 98.6

60 Skott

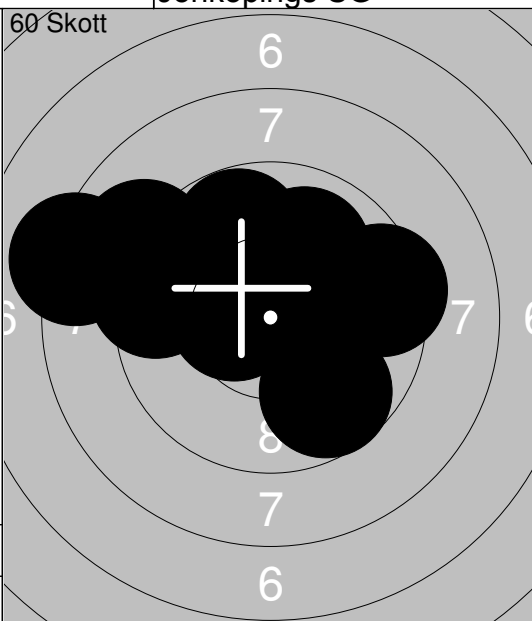

11: 10.1 ↖  
 12: 8.2 ↖  
 13: 9.8 ↑  
 14: 9.4 →  
 15: \*10.5 ↘  
 16: 10.1 ↗  
 17: 9.7 ↓  
 18: 9.4 ↖  
 19: 9.0 ↖  
 20: 10.0 ↑

Serie 96.2

Total 194.8

60 Skott

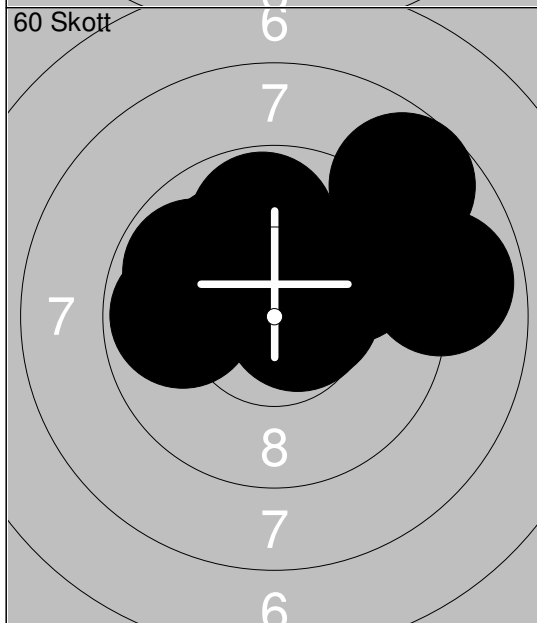

21: \*10.7 →  
 22: \*10.5 →  
 23: 8.7 ↗  
 24: 9.9 ↗  
 25: 9.8 ↖  
 26: 10.1 ↖  
 27: 9.8 ↑  
 28: 9.8 ←  
 29: 8.9 →  
 30: \*10.4 ↗

Serie 98.6

Total 293.4

60 Skott

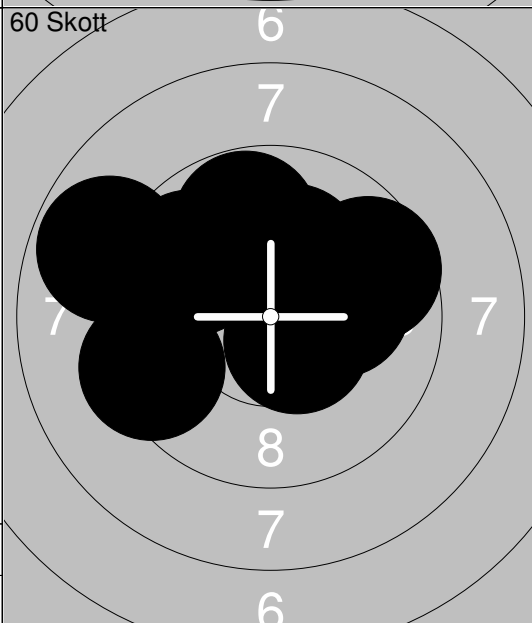

31: 10.1 →  
 32: 8.8 ↖  
 33: \*10.2 ↑  
 34: \*10.5 ↓  
 35: 9.8 ↖  
 36: 9.8 ↑  
 37: \*10.6 →  
 38: 9.4 ←  
 39: 9.6 →  
 40: \*10.3 ↗

Serie 99.1

Total 392.5

60 Skott

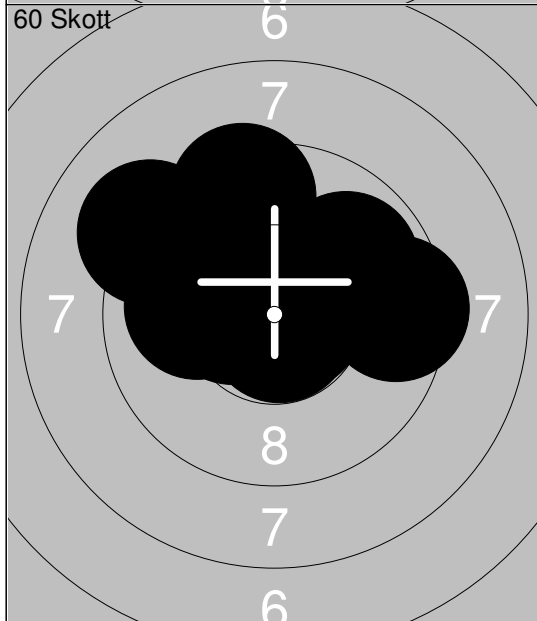

41: 9.5 →  
 42: \*10.4 ↑  
 43: \*10.8 ↓  
 44: 9.5 ↑  
 45: 9.9 ↗  
 46: 9.1 ↖  
 47: \*10.7 →  
 48: \*10.4 ↖  
 49: 10.0 ←  
 50: \*10.2 ↘

Serie 100.5

Total 493.0

60 Skott

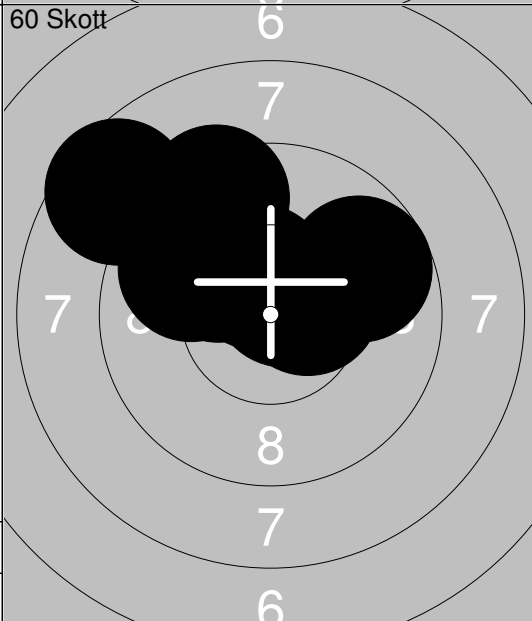



51: \*10.5 →  
 52: 9.9 ↖  
 53: 8.6 ↖  
 54: 9.4 ↑  
 55: 10.1 ↖  
 56: 9.7 ↗  
 57: \*10.6 ↗  
 58: \*10.5 ↑  
 59: 9.5 ↖  
 60: 9.8 ↖

Serie 98.6

Total 591.6

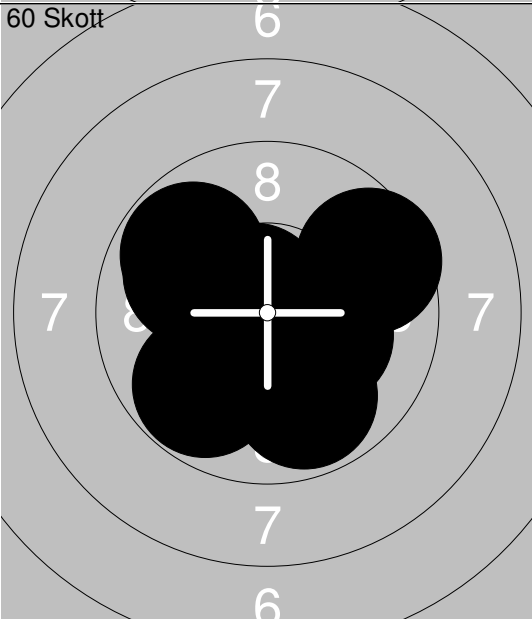
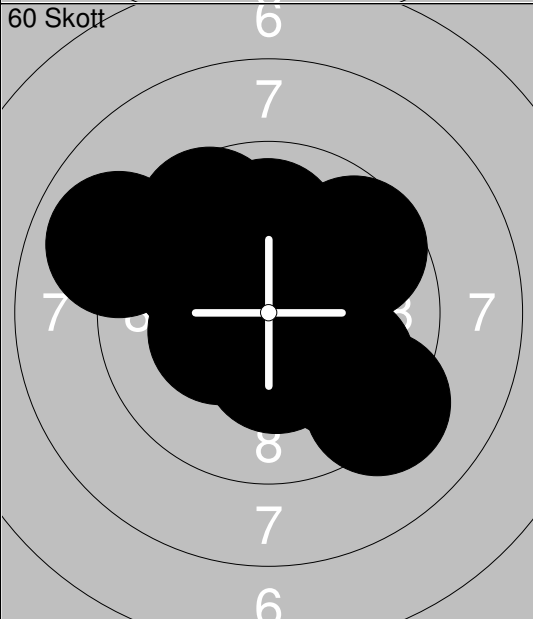

60 Skott		1: 9.5 ↗ 2: *10.9 ↘ 3: 9.4 ↑ 4: 9.7 ↘ 5: 9.5 ← 6: *10.5 ↗ 7: 9.6 ↗ 8: 10.1 ↗ 9: 9.3 ↓ 10: *10.8 ↘	60 Skott		11: 8.9 ↓ 12: 10.1 ↘ 13: 9.3 ↖ 14: 9.7 → 15: *10.4 ↗ 16: 10.1 ↘ 17: *10.3 ↘ 18: 9.8 ← 19: 9.6 ↖ 20: 9.7 ↑
	Serie 99.3			Serie 97.9	
	Total 99.3			Total 197.2	

60 Skott		21: *10.7 ↘ 22: 9.8 ↖ 23: 9.8 ↓ 24: 10.0 ↖ 25: 10.1 ↓ 26: 9.6 → 27: 9.8 ↓ 28: *10.7 ↘ 29: *10.3 ↘ 30: *10.2 →	60 Skott		31: *10.4 ↓ 32: 10.0 ↑ 33: 8.9 ↖ 34: *10.3 ↘ 35: 9.2 ↘ 36: 9.9 ↘ 37: *10.5 → 38: 9.6 ↗ 39: 9.6 ↗ 40: 10.0 ↖
	Serie 101.0			Serie 98.4	
	Total 298.2			Total 396.6	

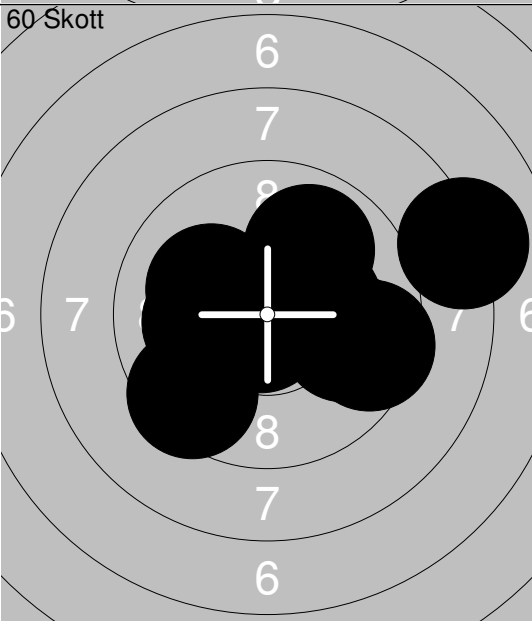
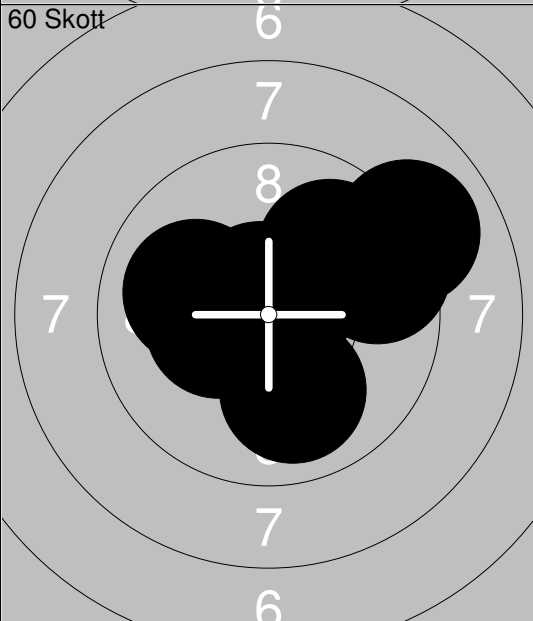
60 Skott		41: 10.1 ↖ 42: *10.7 ↘ 43: *10.2 ↘ 44: 10.1 ← 45: 9.5 ↓ 46: *10.3 → 47: 9.9 ↗ 48: 8.1 → 49: 9.5 → 50: 9.8 →	60 Skott		51: 9.9 ↗ 52: 10.0 ↓ 53: *10.7 ↘ 54: *10.8 ↗ 55: 10.0 ↖ 56: *10.7 ↗ 57: 9.0 ↗ 58: *10.7 ↖ 59: *10.3 ↘ 60: 9.5 →
	Serie 98.2			Serie 101.6	
	Total 494.8			Total 596.4	